

Bulletin No. GPB3T04B

Installation of Protocol Adapter Assembly for Aurora Vending

Purpose

This bulletin contains instructions to install a Protocol Adapter Assembly (PAA), for use with the Aurora Currency Validator, into a Host vending machine. The PAA allows Aurora to communicate with the Host controller, and it provides the cables that connect Aurora to the Host vending machine.

Scope

This bulletin applies to customers who replace their GI or GII Currency Validator with an Aurora Currency Validator and require a PAA. To determine the appropriate PAA and Currency Validator protocol requirements, refer to **Table 1**.



Note: If Host controller uses Multi-Drop Bus (MDB), V1 RS-232 or V2.2 RS-232 protocols, the Protocol Adapter Assembly is not required for installation. For these protocols, the cable from Host controller can be connected to Currency Validator's MDB or RS-232 connector. For MDB and RS-232 connector pin-signal assignments, refer to *Installation Guide for Aurora Currency Validator*(GPT PN 899A013).

Table 1. Aurora Protocol Summary Chart

Protocol of Host Machine	Protocol Adapter Assembly – Part Number Required	Currency Validator – Protocol Required
24V AC/DC High-Level Pulse	GPT PN 350P0001-1	V1 or V2.2 RS-232
110/220 VAC High-Level Pulse	GPT PN 350P0001-2	V1 or V2.2 RS-232
A2A/A2	GPT PN 350P0001-3	V1 or V2.2 RS-232
MDB	PAA is not required.	MDB
V2.2 RS-232	PAA is not required.	V2.2 RS-232
V1 RS-232	PAA is not required.	V1 RS-232

Required Items

The items required for this procedure include:

1. Program Specification Sheet for your Currency Validator.
2. Protocol Adapter Assembly:



Note: Only one of the following items is required. To determine the proper Protocol Adapter Assembly for your unit, refer to Program Specification Sheet.

- 24V AC/DC High-Level Pulse Protocol Adapter (GPT PN **350P0001-1**),
 - 110/220 VAC High-Level Pulse Protocol Adapter (GPT PN **350P0001-2**), or
 - A2A/A2 Protocol Adapter (GPT PN **350P0001-3**).
3. **Installation Guide for Aurora Currency Validator**, publication number G3M2087 (GPT PN **899A0013**).
 4. Extension Cable for new installations only (not supplied – contact GPT Sales Department for the appropriate cable for your installation).



Note: Verify that Part Number/Protocol ID label on cover of Protocol Adapter Assembly identifies appropriate protocol (i.e., 24 VAC High-Level Pulse, 115V VAC High-Level Pulse or A2A/A2) for your host machine (**Figure 1**).



Figure 1. Protocol Adapter Assembly – Label Identification

Protocol Adaptor Assembly Procedure

To prepare and install a Protocol Adaptor Assembly into a Host machine, follow these steps:



WARNINGS:

1. PERSONAL INJURY AND/OR DAMAGE TO EQUIPMENT MAY RESULT BY APPLYING INCORRECT VOLTAGE TO THE CURRENCY VALIDATOR. ONLY APPLY VOLTAGE AS SPECIFIED ON THE **CE/WARNING** LABEL FOUND ON THE BOTTOM ON THE CURRENCY VALIDATOR.
2. REDUCE AND/OR PREVENT RISK OF ELECTRIC SHOCK. DO NOT CONNECT POWER TO THE CURRENCY VALIDATOR IN DAMP OR WET ENVIRONMENT.
3. AVOID DANGEROUS SITUATIONS. DO NOT INTRODUCE FLAMMABLE LIQUIDS OR GASES TO MAINTENANCE WORK AREA WHEN CONNECTING OR DISCONNECTING POWER TO CURRENCY VALIDATOR.

1. Disconnect power to Host machine.
2. Disconnect all cables from GI or GII Currency Validator.
3. Remove Currency Validator from Host machine.
4. Remove and retain four screws that secure cover to Protocol Adaptor Assembly; remove cover by lifting it.
5. On Protocol Adaptor Assembly, set DIP Switches (**Figure 2**) to activate required functions indicated in Program Specification Sheet; refer to **Table 1** for DIP Switch definitions.



Note: For DIP-Switches 1 through 8, the **ON** (closed) setting is toward the number (down), and the **OFF** (open) setting is away from the number (up).

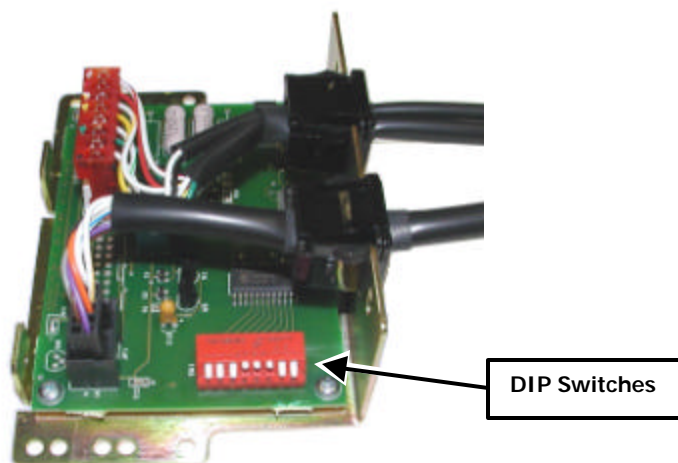

Figure 2. Protocol Adaptor Assembly (Typical) — Location of DIP-Switches 1 through 8



Note: To obtain the settings for DIP-Switches 1 through 8 listed in **Table 1**, refer to Program Specification Sheet for your Currency Validator.

Table 1. DIP-Switch Definitions for Protocol Adapter Assembly

DIP-Switch Number	FUNCTION
1	Bill Enable Sw 1: OFF = disabled ON = enabled
2	Bill Enable Sw 2: OFF = disabled ON = enabled
3	Bill Enable Sw 3: OFF = disabled ON = enabled
4, 5	Pulse Count Multiplier: One of four values can be selected, as follows: (5 - 4) OFF - OFF = Option 1 OFF - ON = Option 2 ON - OFF = Option 3 ON - ON = Option 4
6	Pulse Length: One of two values can be selected, as follows: OFF = Option 1 ON = Option 2
7	Inhibit Logic: OFF = Normal (driven [ON] = L; Isolated [OFF] = H) ON = Inverted (driven [ON] = H; Isolated [OFF] = L)
8	Protocol: OFF = A2A ON = High Level

6. Re-attach and secure cover to Protocol Adapter Assembly with four screws retained in **Step 4**. Preparation of Protocol Adapter Assembly is now completed.

7. Install proper Protocol Adapter Assembly as follows:



Note: For new installations, an extension cable is required for the 9-Pin Credit Relay and Inhibit Connector. Contact GPT Sales Department to obtain the appropriate cable for your application.

- a. For 24 VAC/DC High-Level Pulse Protocol Adapter, make the connections in **Figure 3** ; for connector pin assignments, refer to **Figure 4** .

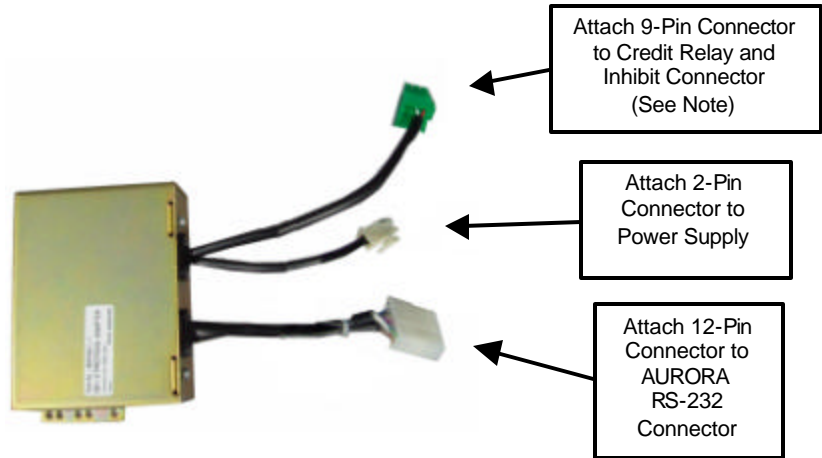

Figure 3. 24 VAC/DC High-Level Pulse Protocol Adapter Assembly — Cable Connections

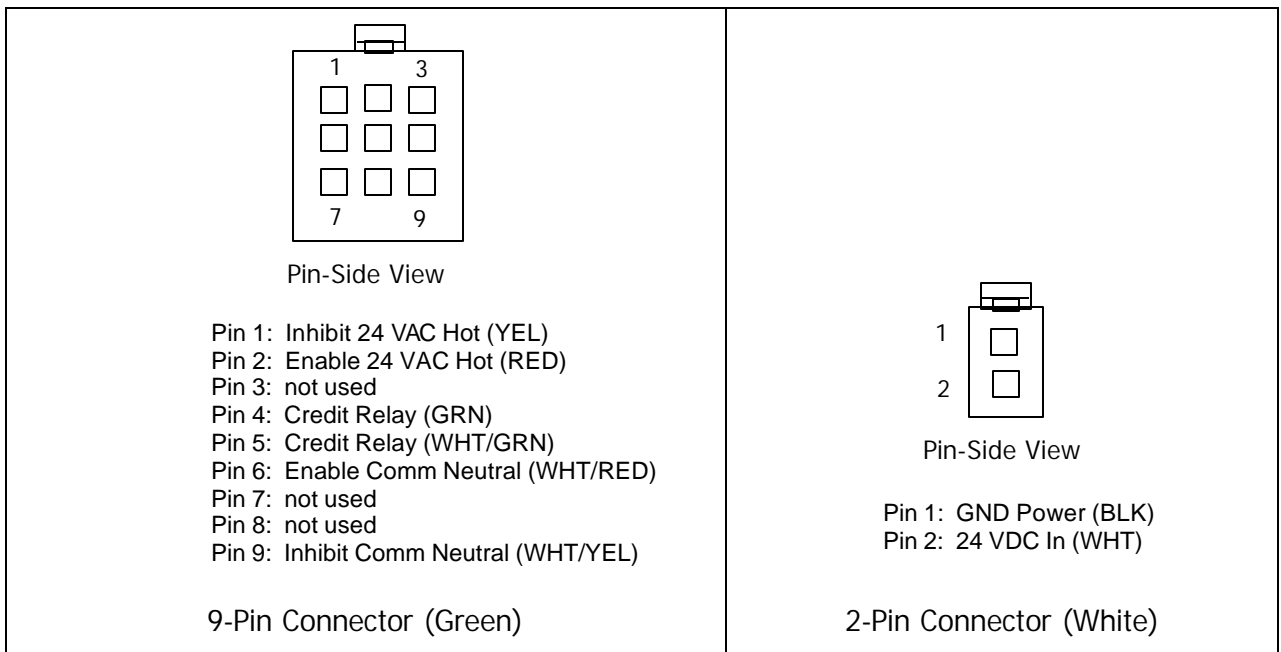

Figure 4. Connector Pin Assignments for 24 VAC/DC High-Level Pulse Protocol Adapter Assembly

- b. For 110/220 VAC/DC High-Level Pulse Protocol Adapter, make the connections in **Figure 5**; for connector pin assignments, refer to **Figure 6**.

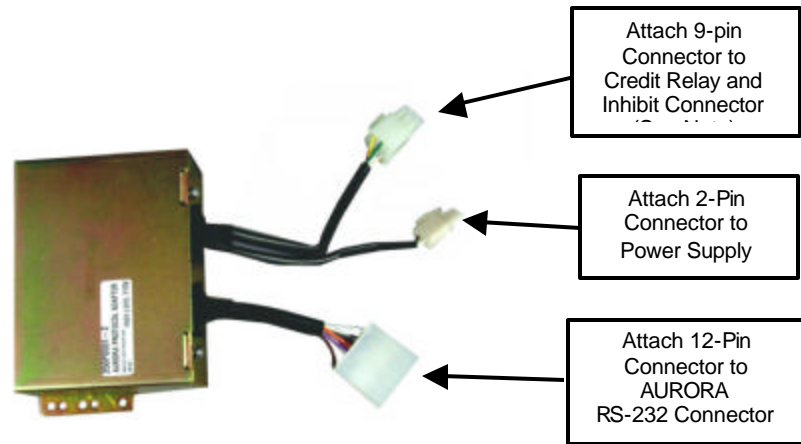

Figure 5. 110/220 VAC High-Level Pulse Protocol Adapter Assembly — Cable Connections

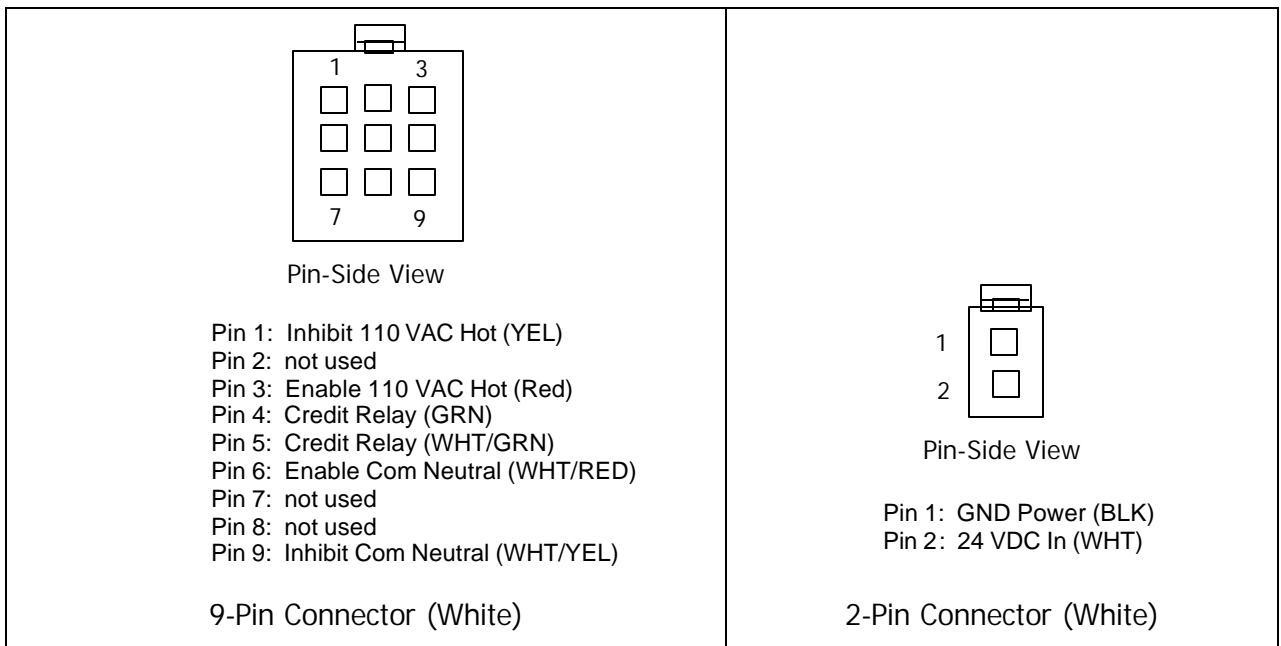

Figure 6. Connector Pin Assignments for 110/220 VAC High-Level Pulse Protocol Adapter Assembly

- c. For A2A/A2 Protocol Adapter Assembly, make the connections in **Figure 7**; for connector pin assignments, refer to **Figure 8**.

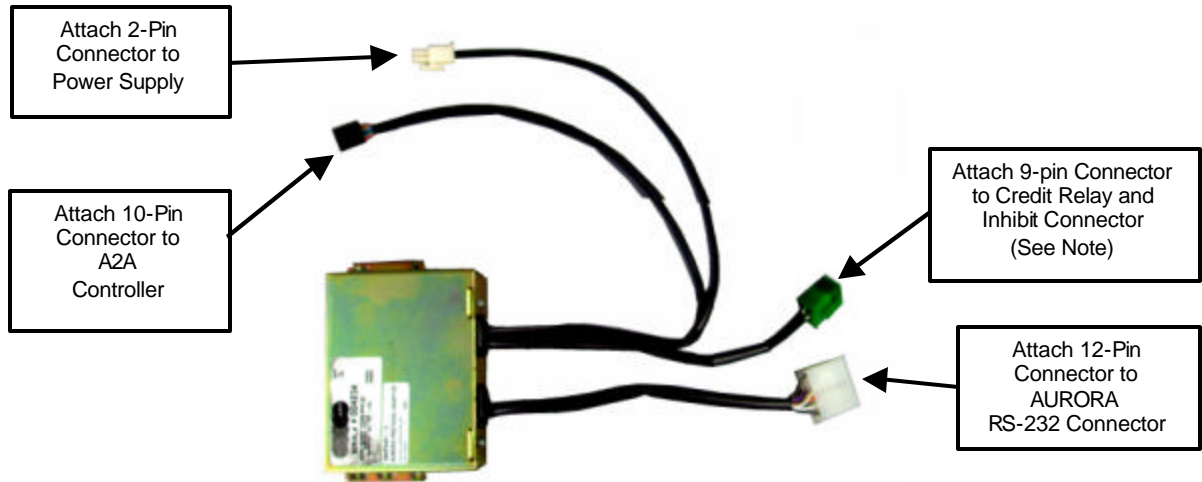
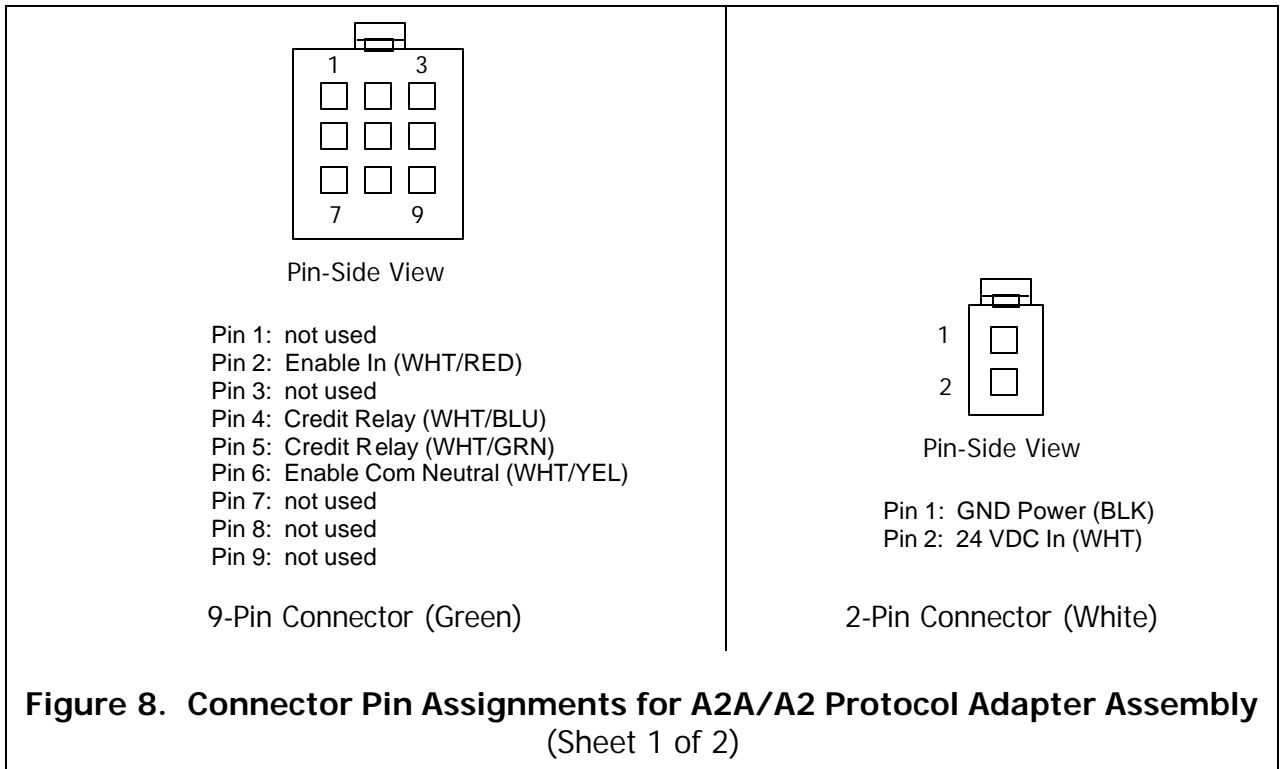

Figure 7. A2A/A2 Protocol Adapter Assembly — Cable Connections



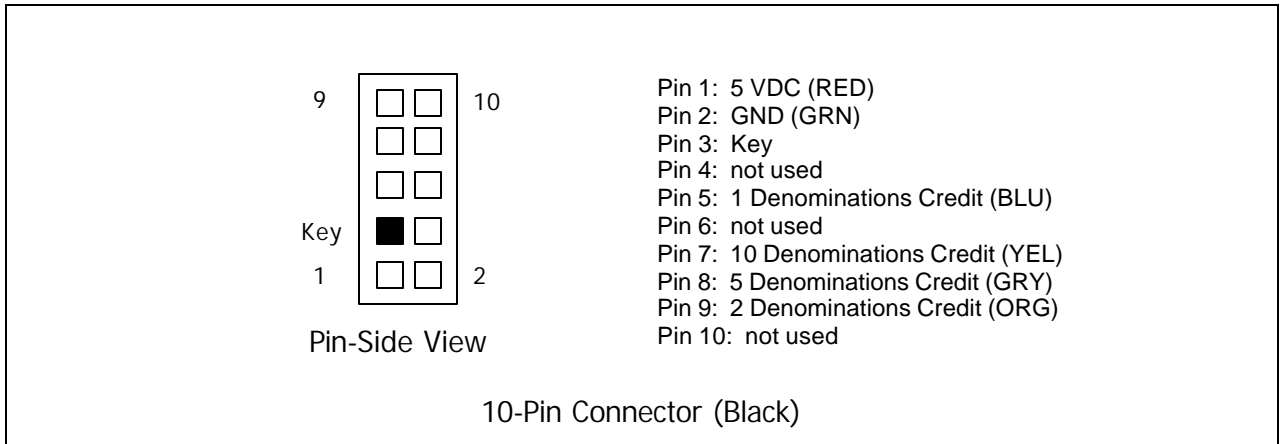

Figure 8. Connector Pin Assignments for A2A/A2 Protocol Adapter Assembly (Sheet 2 of 2)

8. Secure Protocol Adapter Assembly into Host machine.
9. To install the Aurora Currency Validator, refer to ***Installation Guide for Aurora Currency Validator.***



Note: Aurora's Main Cable Assembly has one male and one female 6-Pin MDB connector, and one 12-Pin RS-232 connector. Attach appropriate connector to Host controller (Figures 9 and 10).

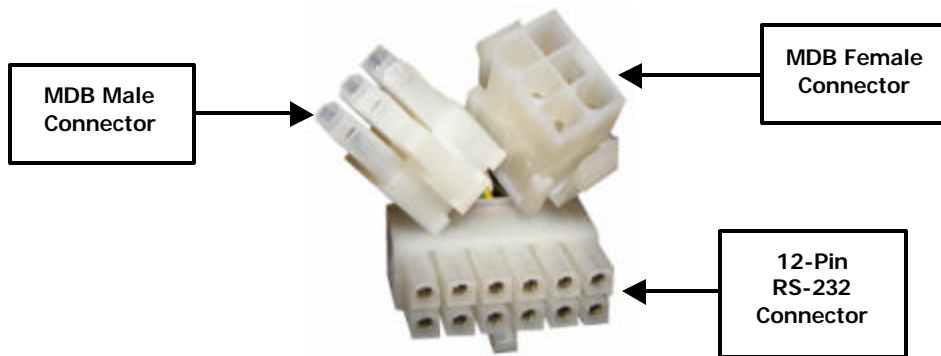
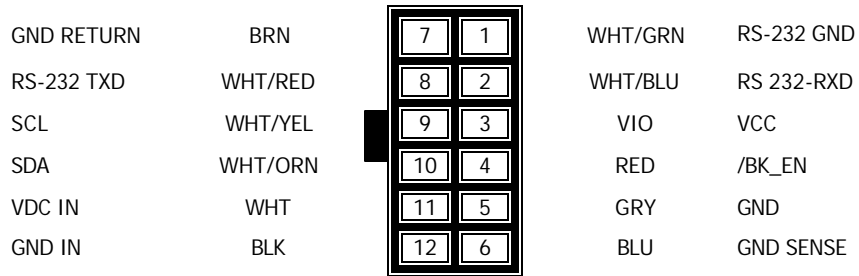
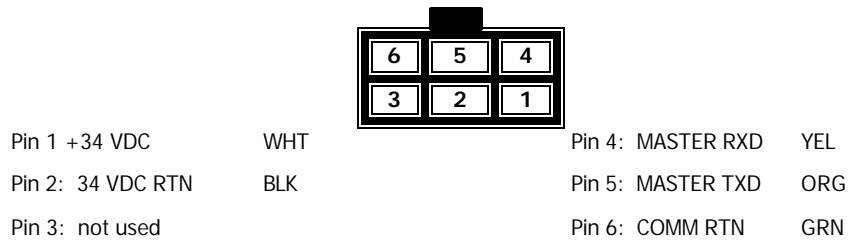

Figure 9. Aurora Main Cable Connectors



RS-232 Connector (Wire-Side View)



MDB Male Connector (Wire-Side View)

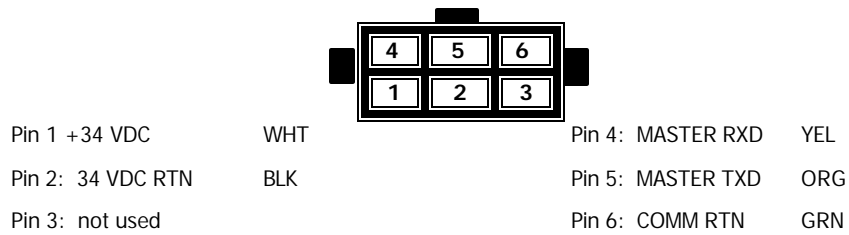

MDB Female Connector (Wire-Side View)

Figure 10. Pin Assignments for Aurora RS-232 and MDB Connectors

This page left intentionally blank.